

COMPT.	DOOR OPENING	INTERIOR	DIVIDE HEIGHT	UPPER DEPTH	LOWER
L1	23"W x 59"H	28.5"W x 72.5"H	30"	14"	23"
L2	35"W x 30"H	43"W x 43"H	-	14"	14"
L3	35"W x 30"H	48"W x 43"H	-	14"	14"
L4	51"W x 18"H	54"W x 27"H	-	14"	14"
L5	24"W x 49"H	33.5"W x 57.75"H	25"	14"	23"
R1	23"W x 59"H	28.5"W x 72.5"H	30"	14"	23"
R2	35"W x 30"H	43"W x 43"H	-	14"	14"
R3	35"W x 30"H	48"W x 43"H	-	14"	14"
R4	51"W x 18"H	54"W x 27"H	-	14"	14"
R5	48"W x 49"H	55"W x 57.75"H	25"	14"	23"

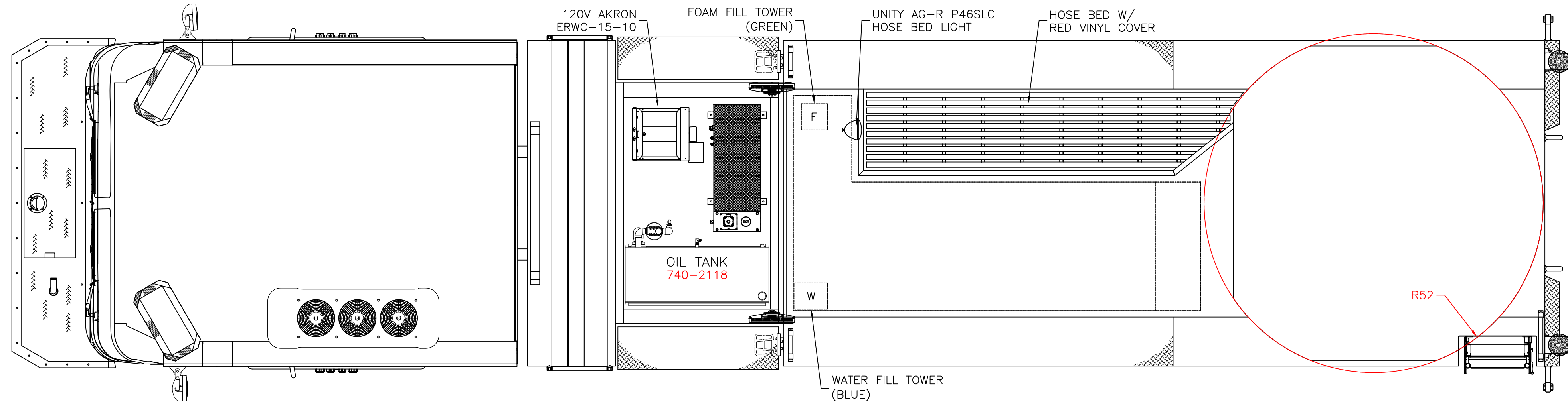

- SHOP INSTRUCTIONS
- ENGINEERED FOR FUTURE FOAM FOAMPRO 2001/2002 SYSTEM
  - NO CUTOUPS ON PANELS
  - FOAM CAPABLE DISCHARGES:
    - 1-1/2" FRONT BUMPER DISCHARGE
    - 1-1/2" CROSSLAY
    - 1-1/2" CROSSLAY
    - 2-1/2" CROSSLAY
  - COMPARTMENT FINISH: LINE-X GRAY
  - SHELVES/TRAYS FINISH: ABRADED
  - INNOVATIVE CONTROLS LIFT DRAINS

ITEM	DESCRIPTION	MODEL #	QTY
A	35' 3 SEC EXTENSION	PEL3-35	1
B	24' 2 SEC EXTENSION	PEL-24	1
C	16' ROOF	DRL-16	2
D	14' COMBO JACKKNIFE	CJL-14	1
E	10' FOLDING ATTIC	FL-10	1
F	4' D-HANDLE PIKE POLE	NHF-4 W/D	2
G	6' PIKE POLE	NHF-6	2
H	8' PIKE POLE	NHF-8	2
I	12' PIKE POLE	NHF-12	2

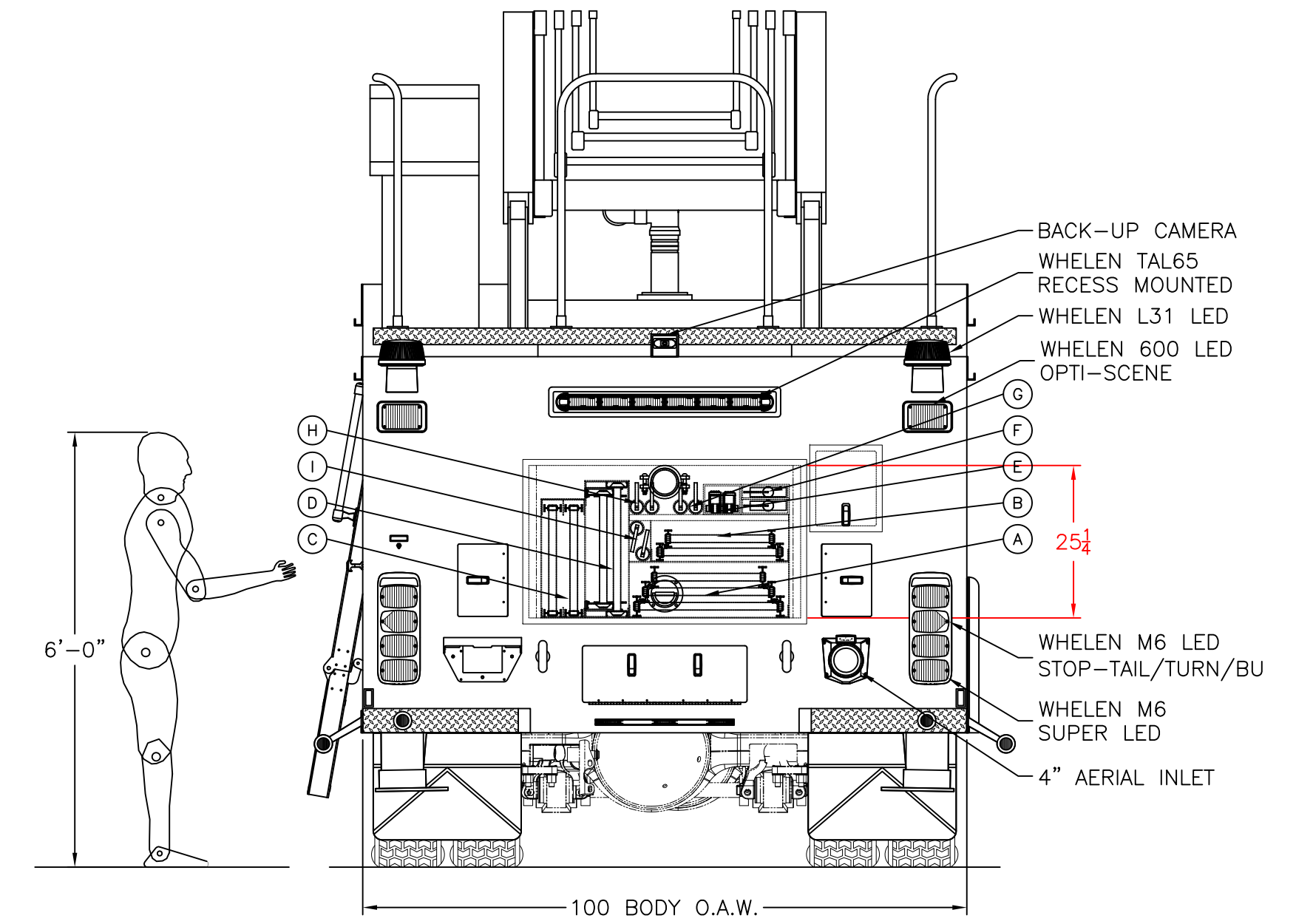
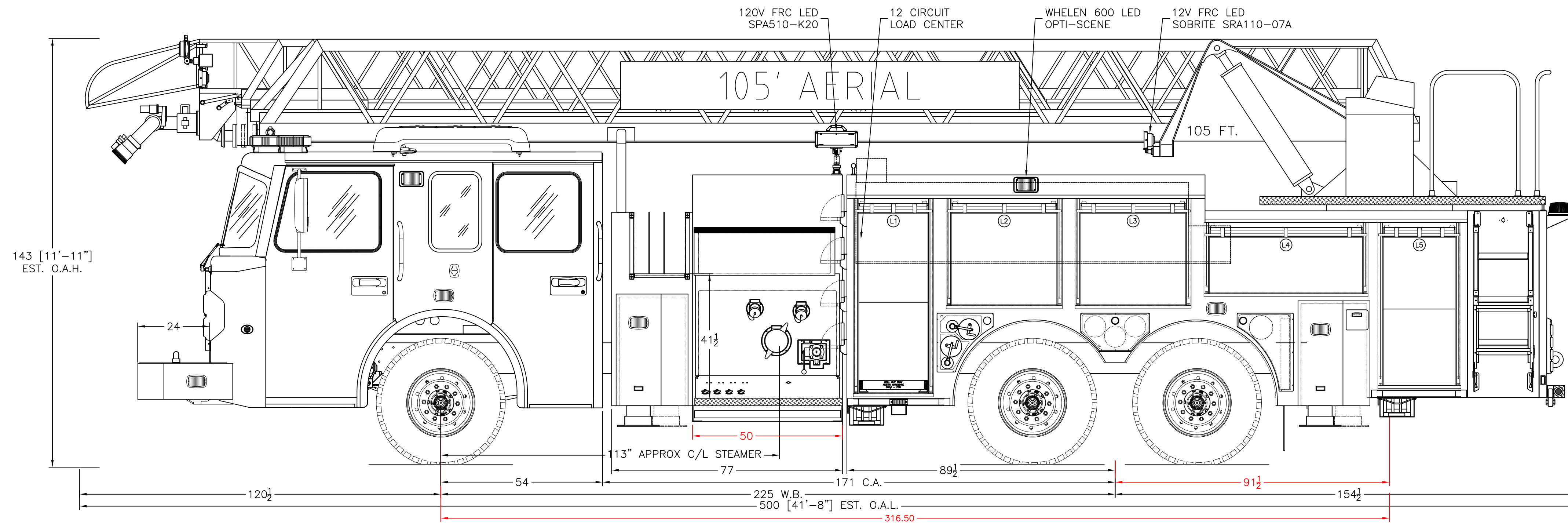

**NOTE:**  
 THIS DRAWING IS THE PROPERTY OF SPARTAN MOTORS USA AND IS TO BE USED ONLY IN REFERENCE TO THE WORK PROPOSED OR CONTRACTED BY SPARTAN MOTORS USA ANY REPRODUCTION IN PART OR IN WHOLE WITHOUT THE WRITTEN PERMISSION OF SPARTAN MOTORS USA IS STRICTLY PROHIBITED.  
 DIMENSIONS SHOWN ARE APPROXIMATE AND ARE SUBJECT TO CHANGE AS MAY BE FOUND NECESSARY DURING CONSTRUCTION. THIS DRAWING MUST BE PLOTTED TO THE PAPER SIZE LISTED IN THE TITLE BLOCK FOR THE LISTED SCALE TO BE VALID.  
 THIS DRAWING IS FOR REFERENCE PURPOSES ONLY. SOME ITEMS MAY OR MAY NOT APPEAR ON THE DRAWING THAT MAY OR MAY NOT BE INCLUDED IN THE SPECIFICATIONS. THE SPECIFICATIONS SHALL BE THE FINAL AUTHORITY TO DETERMINE WHAT IS SUPPLIED ON THE APPARATUS.

REV	INT	DATE	REVISION HISTORY
01	CL	3/22/18	PRE CONSTRUCTION UPDATES
02	KS	8/27/18	CHANGE ORDER #6 UPDATES
03	KS	9/27/18	MADE LOWER R1 COMPARTMENT 23" DEEP

**SHOP PRINT  
 PRE-CONSTRUCTION**

CHASSIS: SPARTAN GLADIATOR MFD FLAT ROOF  
 ENGINE: CUMMINS X15 50SHIP WITH ALLISON 4000 EVS  
 PUMP: HALE QMAX K-SERIES 2000 GPM  
 WATER TANK: 480 U.S. GAL  
 FOAM CELL: 20 U.S. GAL  
 BODY MATERIAL: 1/8" ALUMINUM  
 HOSE BED: 1000' OF 5" / 39 CUBIC FEET  
 GENERATOR: HARRISON 10KW MCR  
 COMPARTMENTS: 131 CUBIC FEET



SPARTAN STOCK	
SNYDER, NE	
MODEL:	105' REAR MOUNT AERIAL
DEALERSHIP:	SPARTAN MOTORS, USA, INC.
SCALE: 1/2" = 1'	DRAWN BY: CL DATE: 3/22/18
SIZE: 24" X 36"	DRAWING NO: S4859 REV: 03
SHEET: 1 OF 1	